

Pergola

Ringenbach

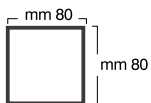

SEZIONE DEI PROFILI



TRAVE PERIMETRALE E PIANTONE

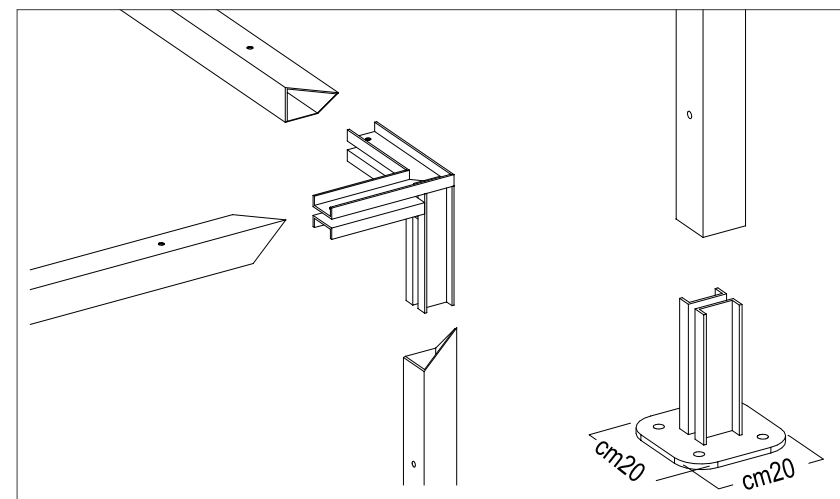

BULLONERIA

PARTE DA MONTARE	BULLONE	QUANTITÀ
<input type="checkbox"/> TRAVE con GIUNTO ANGOLARE	M 8x35 T.S.	8
<input type="checkbox"/> PIEDE con PIANTONE	M 8x35 T.S.	4
<input type="checkbox"/> PIANTONE con GIUNTO ANGOLARE	M 8x35 T.S.	4
<input type="checkbox"/> TAPPINI IN GOMMA		16
<input type="checkbox"/> TRAVE FRANGITRATTA	autoforanti 4.8x35	16
<input type="checkbox"/> TEFLON SU TRAVE FRANGITRATTA	autoforanti 4.8x35	
<input type="checkbox"/> PROFILIA "T" su perimetro	autoforanti 4.2X16	4
<input type="checkbox"/> LAME SU PROFILO A "T"	PERNI standard	2 PER LAMA
<input type="checkbox"/> LAMA CON PIASTRE TRIANGOLARI SU PROFILO A "T"	PERNI LUNGHI 8X60	4
<input type="checkbox"/> PROFILO A "L" CON LAME	1 PERNO + 3 RONDELLE (per ogni foro)	2 PER LAMA
<input type="checkbox"/> PROFILO A "L" CON LAME CON PIASTRA TRIANGOLARE	PERNI 8X60 + 3 RONDELLE (per ogni foro)	2 PER LAMA
<input type="checkbox"/> ARGANO DI MANOVRA	Autoforanti 4.8X70	4
<input type="checkbox"/> ASTA PER ARGANELLO		
<input type="checkbox"/> PIASTRE QUADRATE CON FORO	autoforanti 4.8X35	12
<input type="checkbox"/> COMPENSATORI IN TEFLON		3
<input type="checkbox"/> 2 BRACCETTI (+ 2 perni corti e 1 perno lungo)		
<input type="checkbox"/> PIASTRE A GOCCIA		2
<input type="checkbox"/> PIASTRA A GOCCIA (con perno)		1
<input type="checkbox"/> LEVE con piastre a goccia	M 10X40 + dado autobloccante	2
<input type="checkbox"/> LEVE con piastre triangolari	M 10X30 + dado autobloccante	2
<input type="checkbox"/> PISTONE		

Individuare le travi perimetrali, la trave frangitratta e posizionarli come indicato

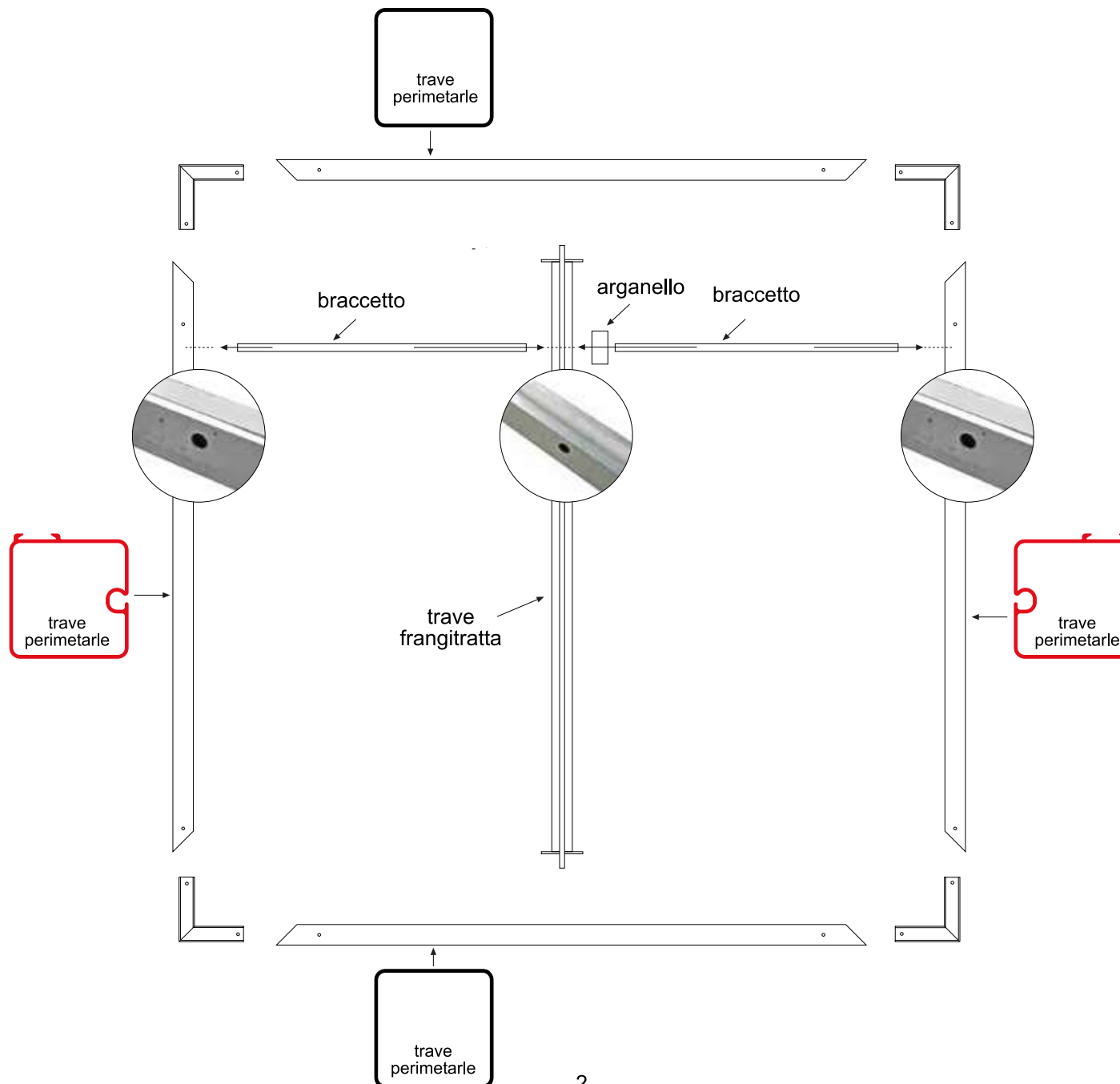

1)



M 8x35 T.S.

Avvitare i bulloni negli inserti filettati dei giunti angolari facendo attenzione a **NON STRINGERE I BULLONI**

2)



Collegare i giunti angolari con le travi perimetrali

3)

Bloccare le travi perimetrali ai giunti angolari stringendo il bullone precedentemente avvitato negli inserti filettati

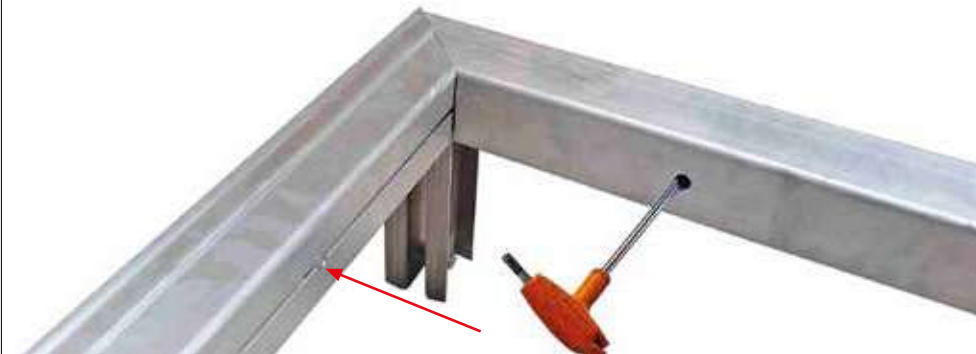

4)

Inserire i tappini in gomma



5)



6)

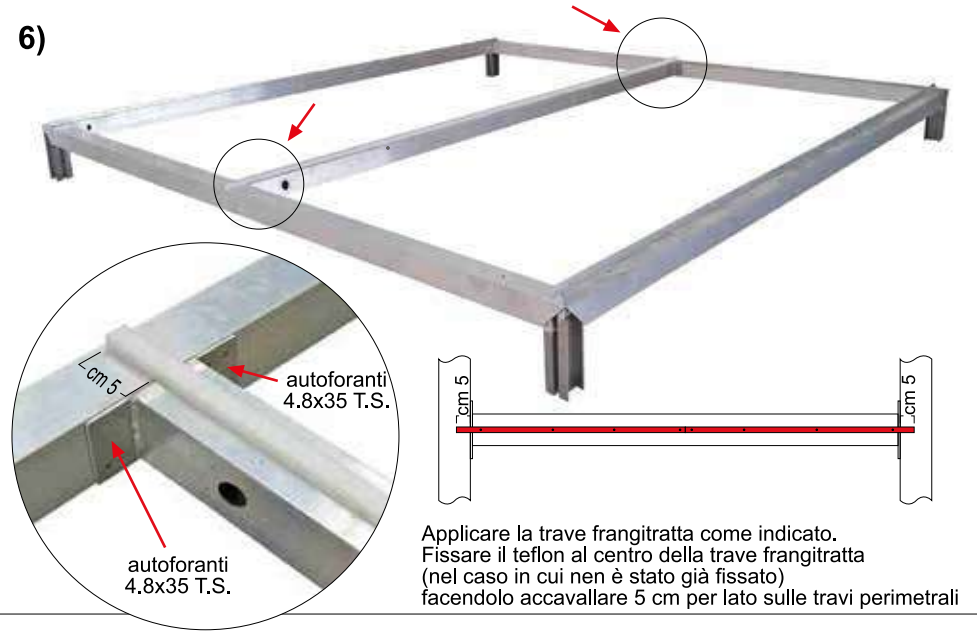

7)

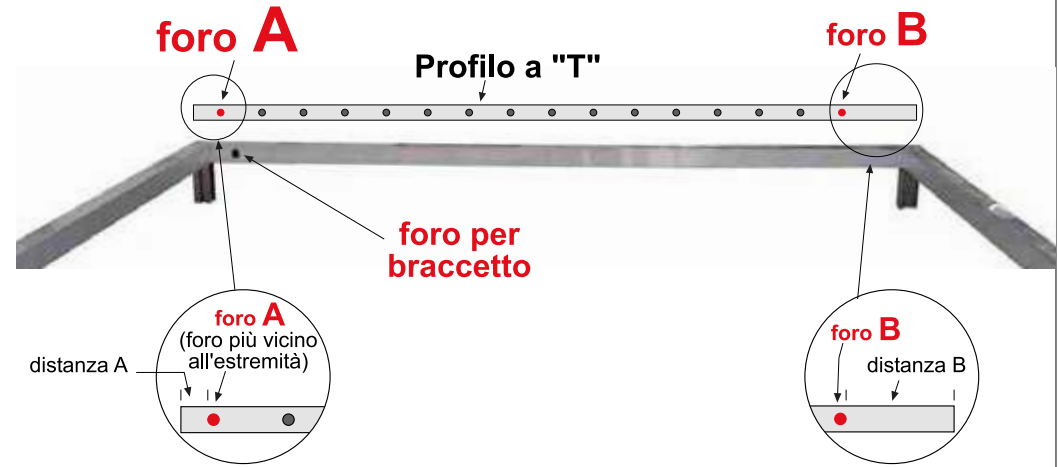
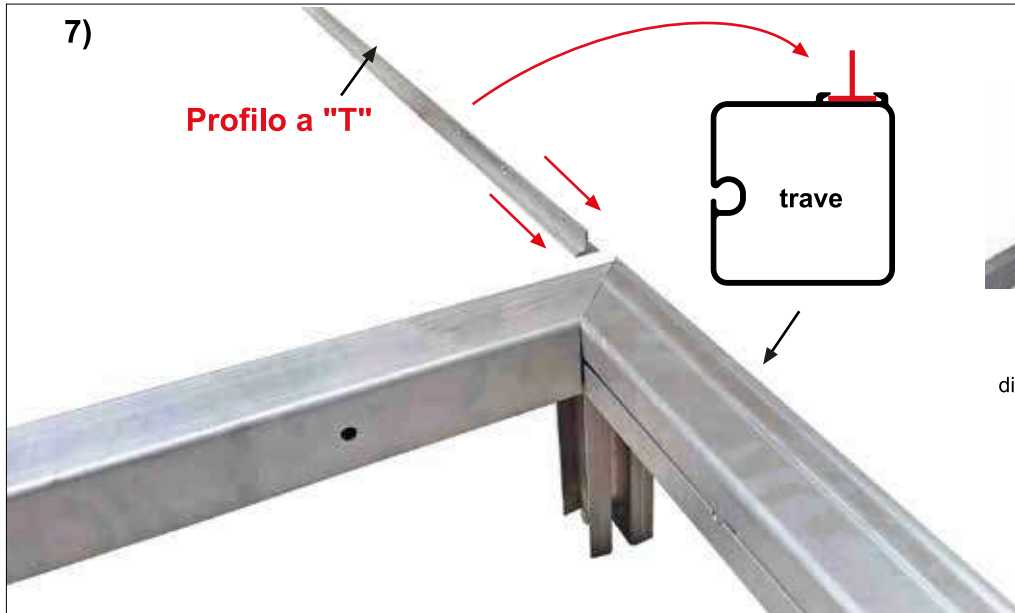

Inserire i profili a "T" nell'apposita scanalatura situata sul lato superiore della trave perimetrale, facendo attenzione che il **foro A** (foro + vicino all'estremità del profilo a "T") sia rivolto verso i fori per braccetti delle travi perimetrali

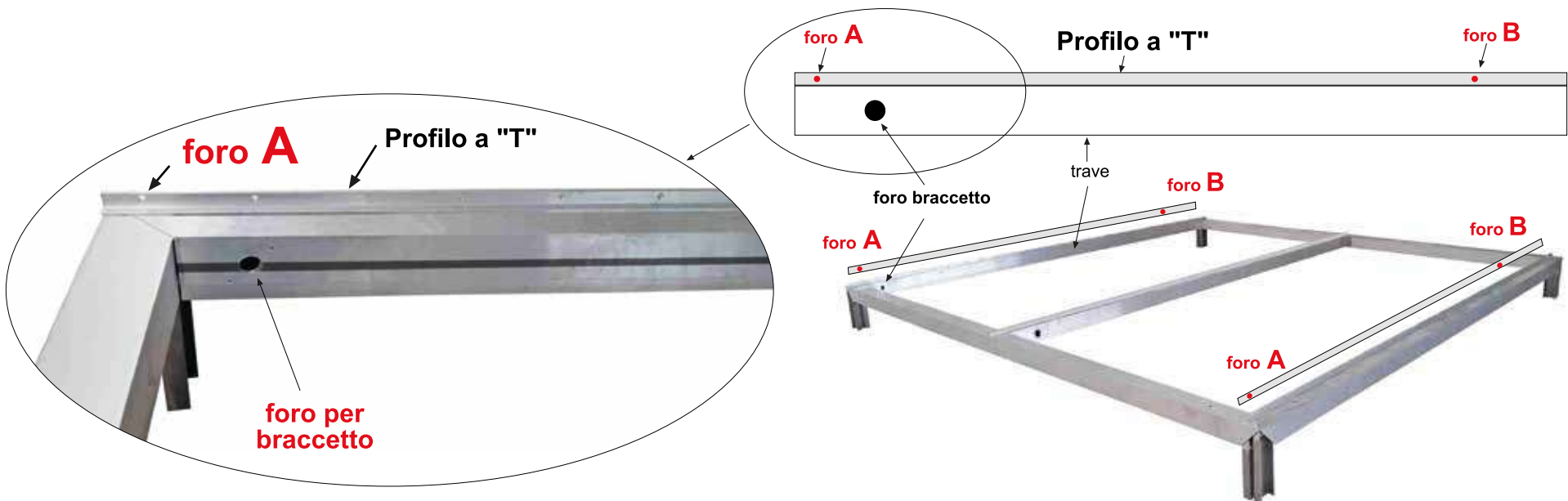

8)

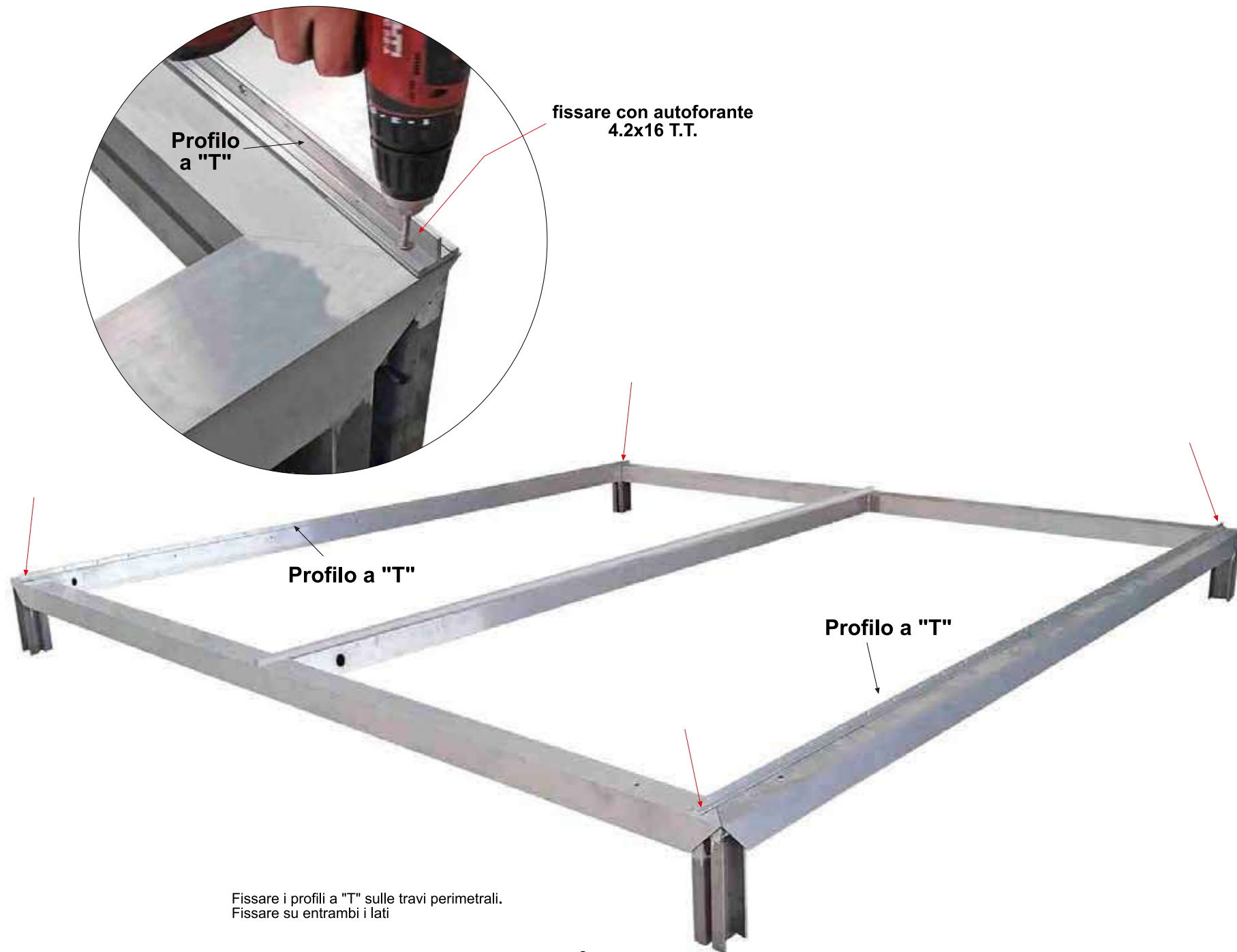

Fissare i profili a "T" sulle travi perimetrali.
Fissare su entrambi i lati

9)

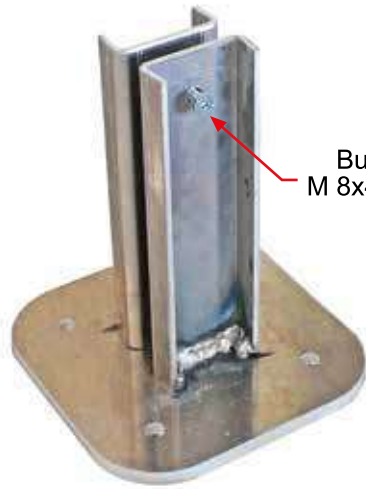

Bullone
M 8x40 T.S.

Avvitare il bullone nell'inserto filettato dei piedi



Inserire il piantone

10)



Blocare il piede al piantone stringendo il bullone precedentemente avvitato



TAPPO

Inserire il tappino in gomma

11)

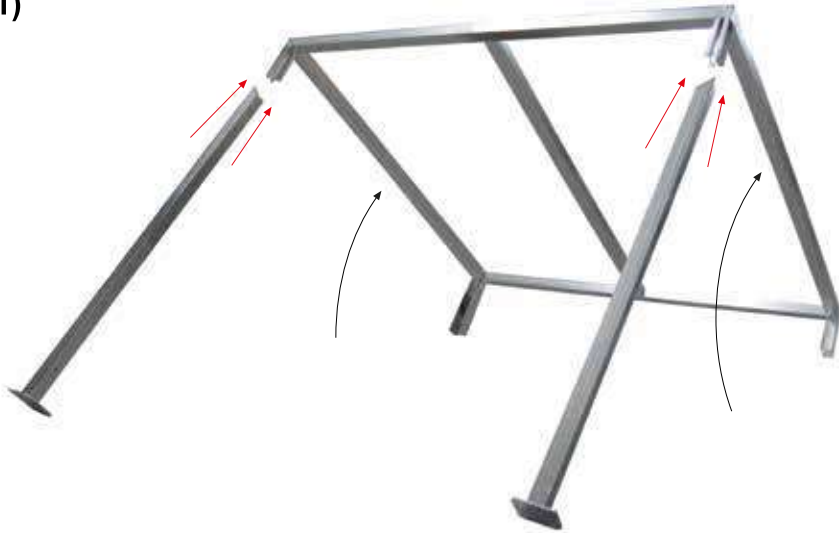

Sollevarre la struttura da un lato ed inserire i piantoni con i relativi piedi

12)



Sollevarre la struttura dall'altro lato ed inserire gli altri 2 piantoni con i relativi piedi

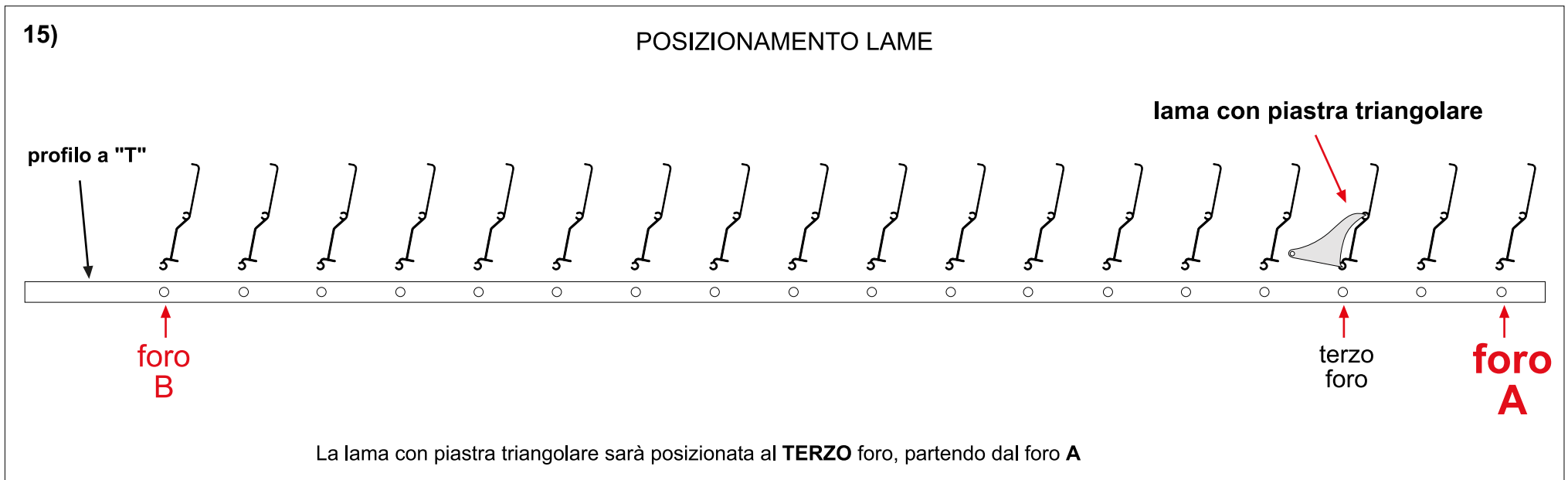
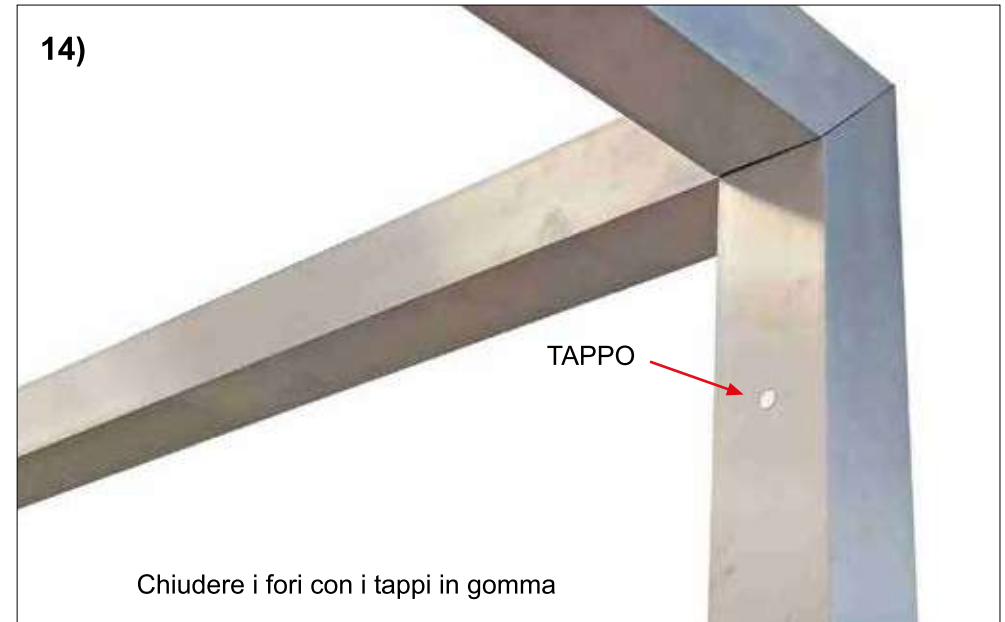

16)



lama



foro A



21)

profilo a "L" con fori



Preparare il profilo a "L" con fori facendo attenzione che il primo foro con distanza dal bordo 130 mm sia rivolto verso il foro A del profilo a "T".

profilo a "L" con fori

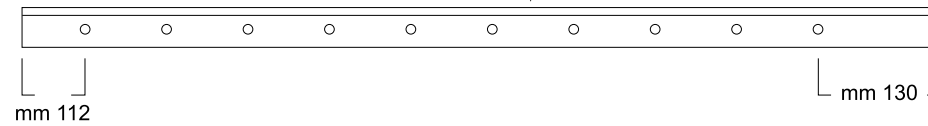

22)

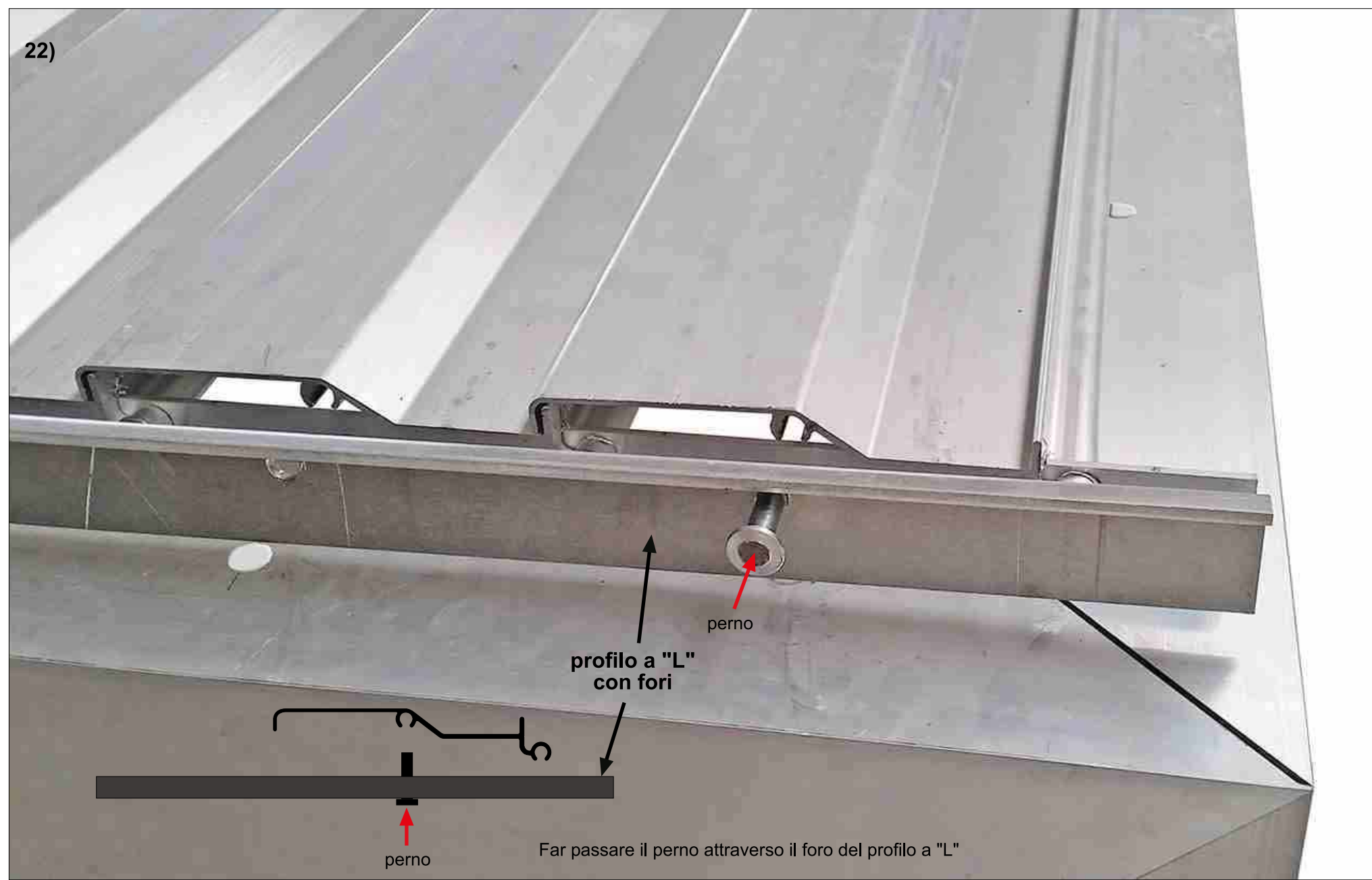

23)

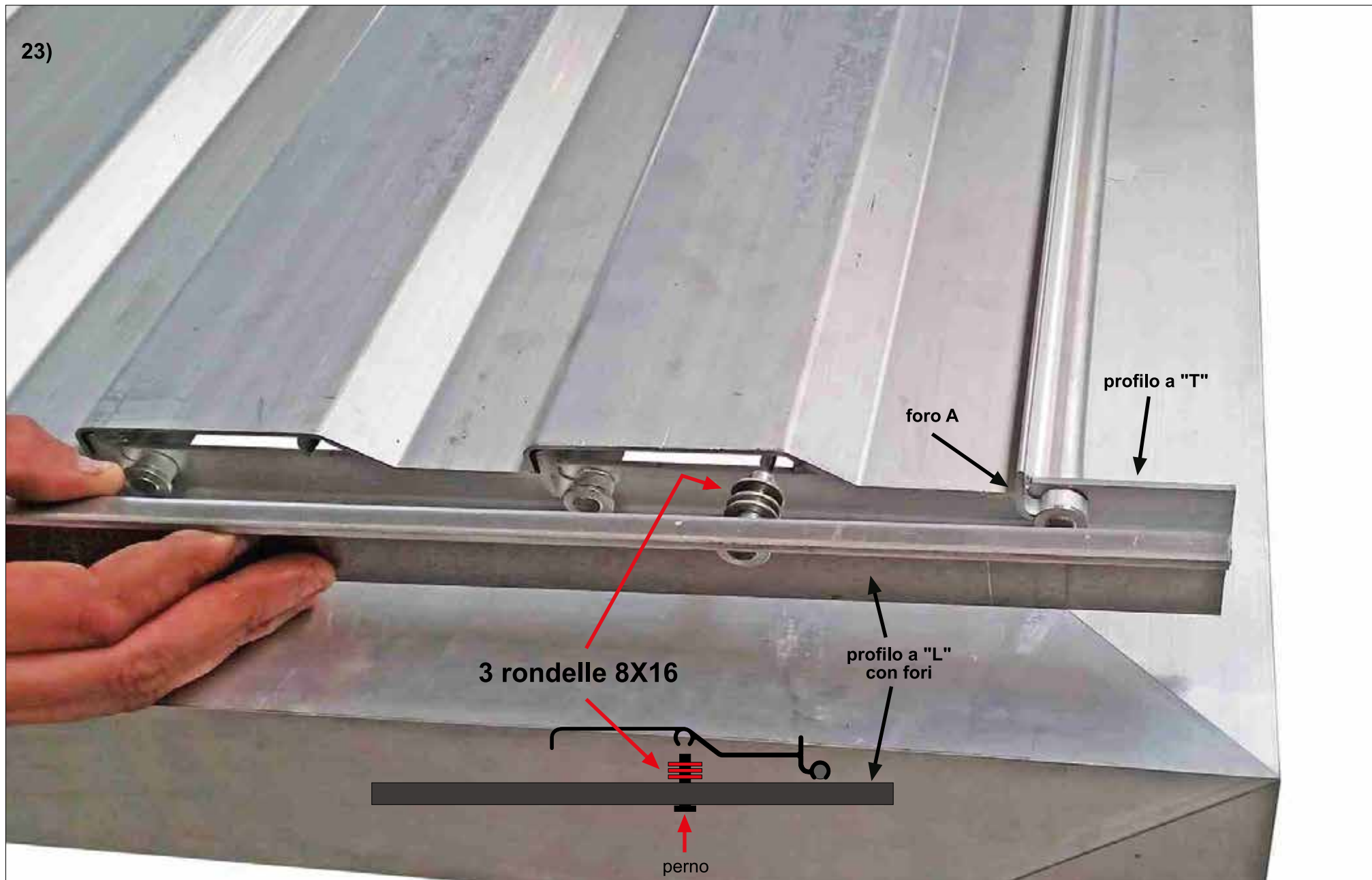

24)



25)

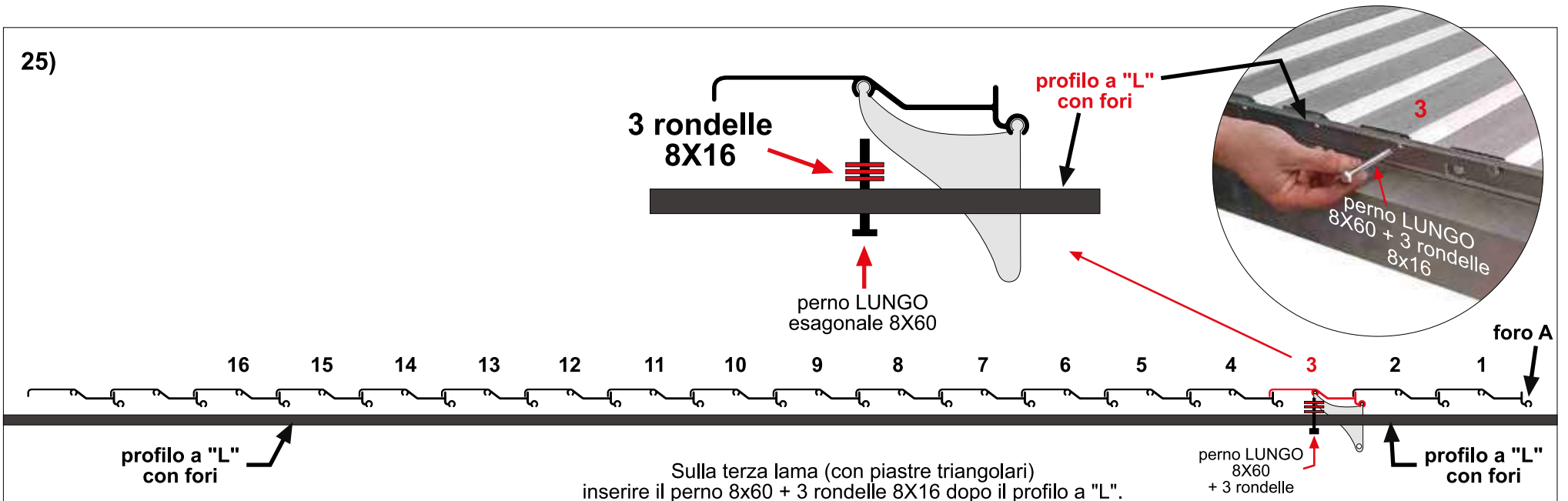

26)

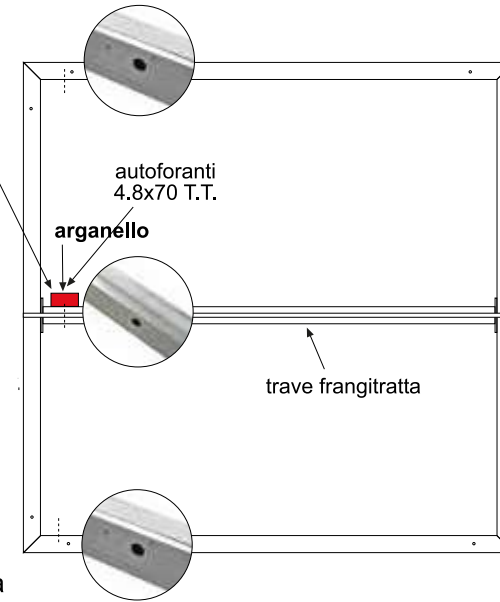
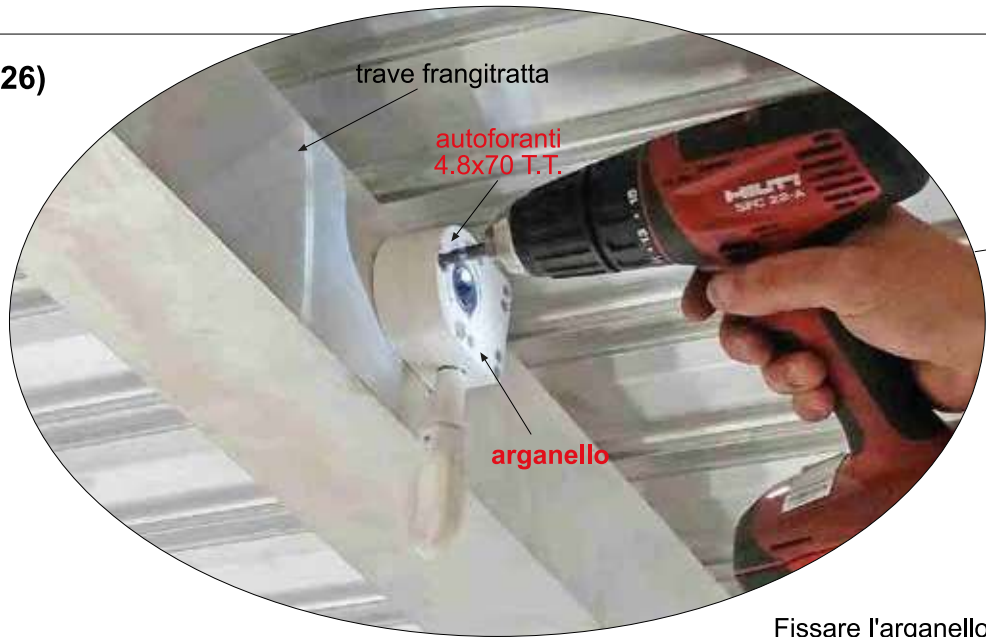

Fissare l'arganello alla trave frangitratta

27)

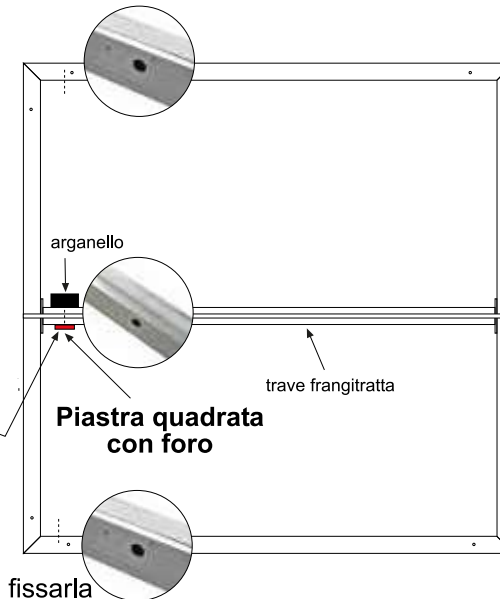
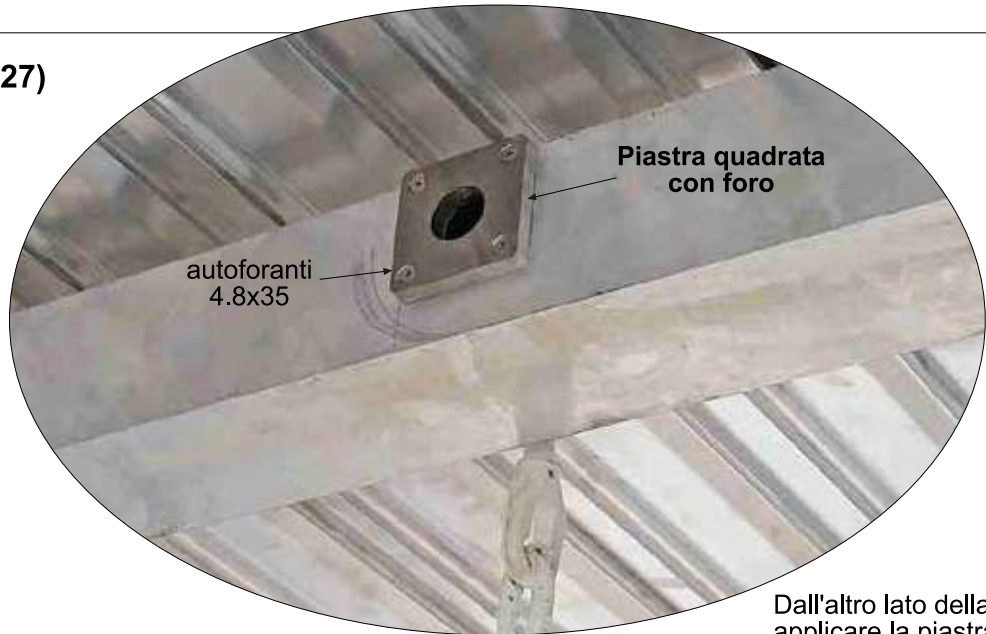

Dall'altro lato della trave frangitratta, applicare la piastra quadrata con foro e fissarla

28

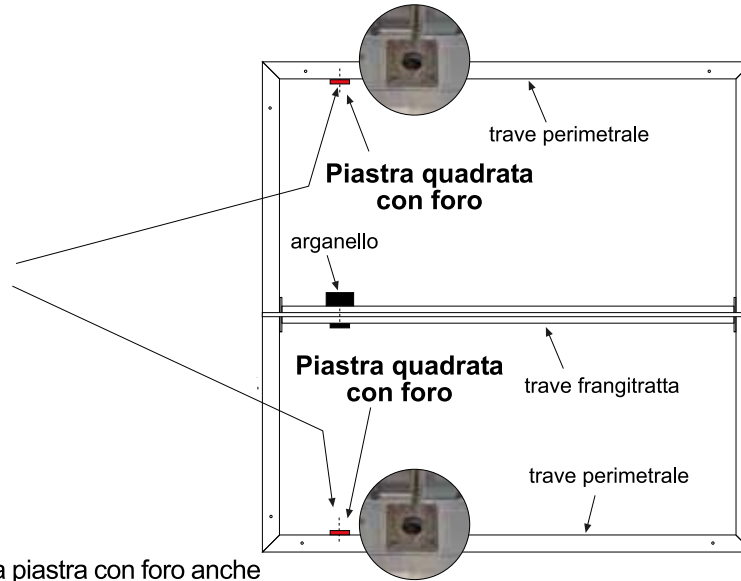
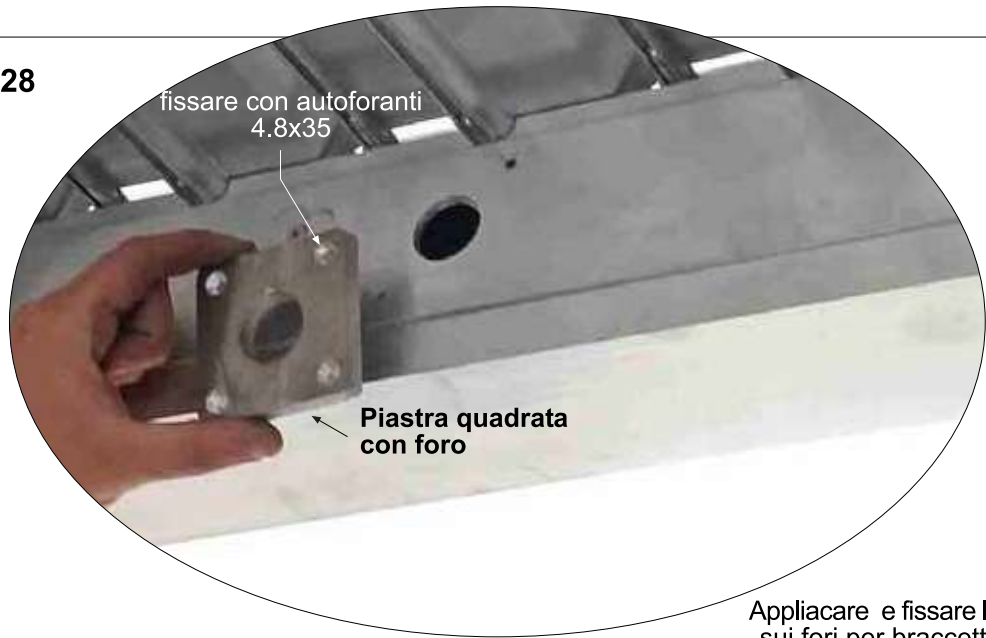

Applicare e fissare la piastra con foro anche sui fori per braccetti delle travi perimetrali

29)

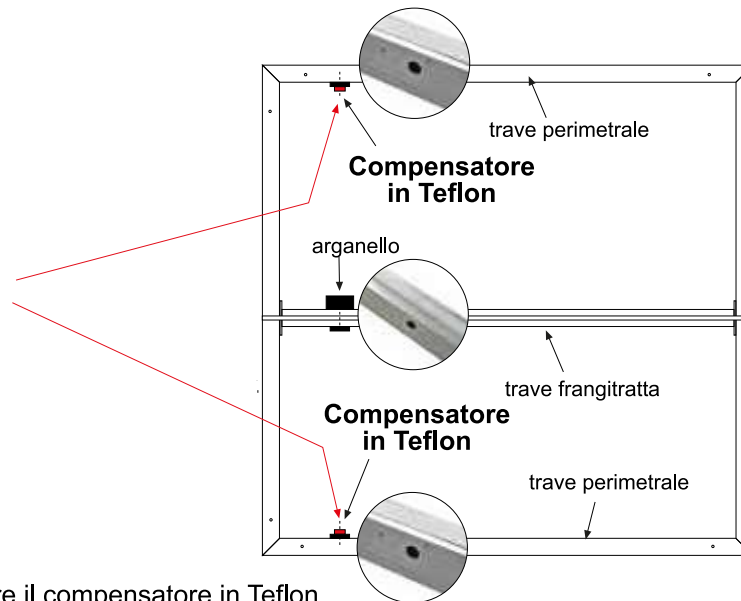
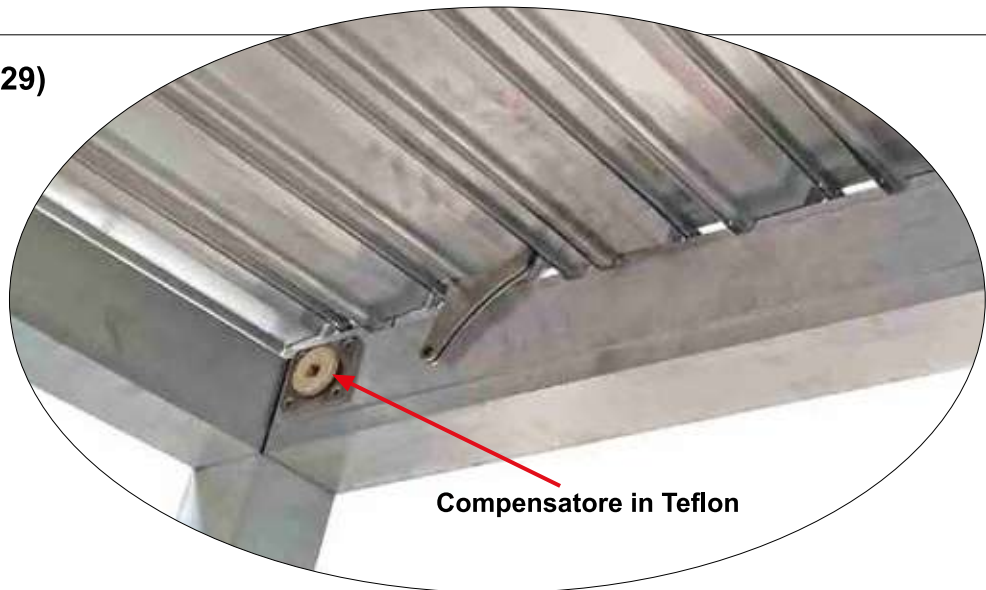

Agendo solo sulle piastre quadrate con foro delle travi perimetrali, applicare il compensatore in Teflon

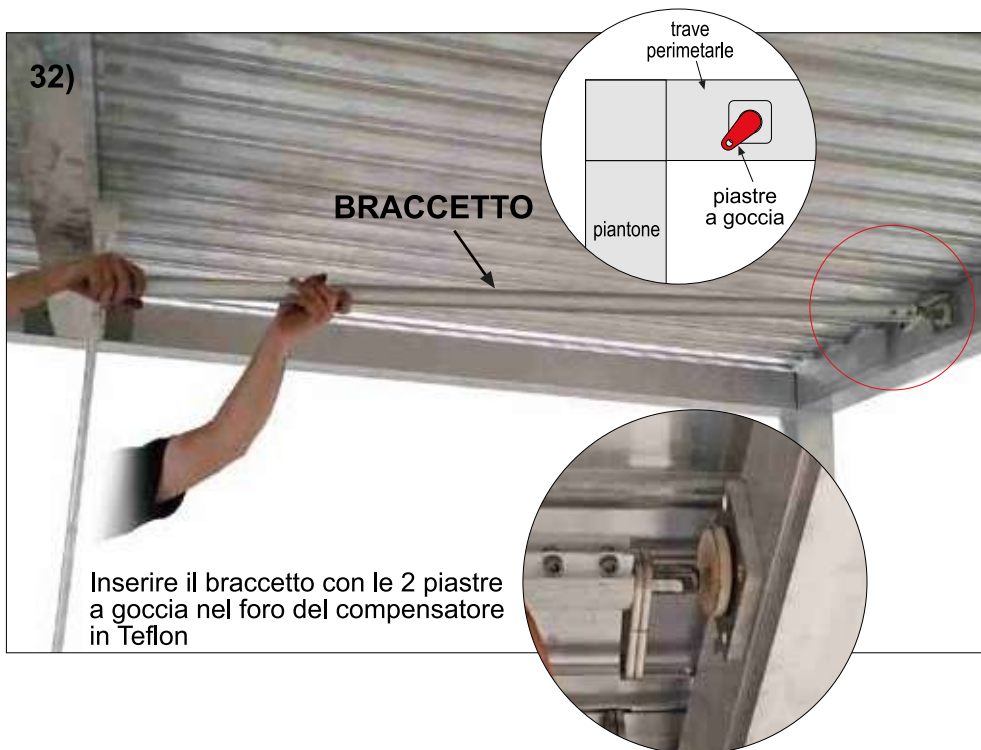
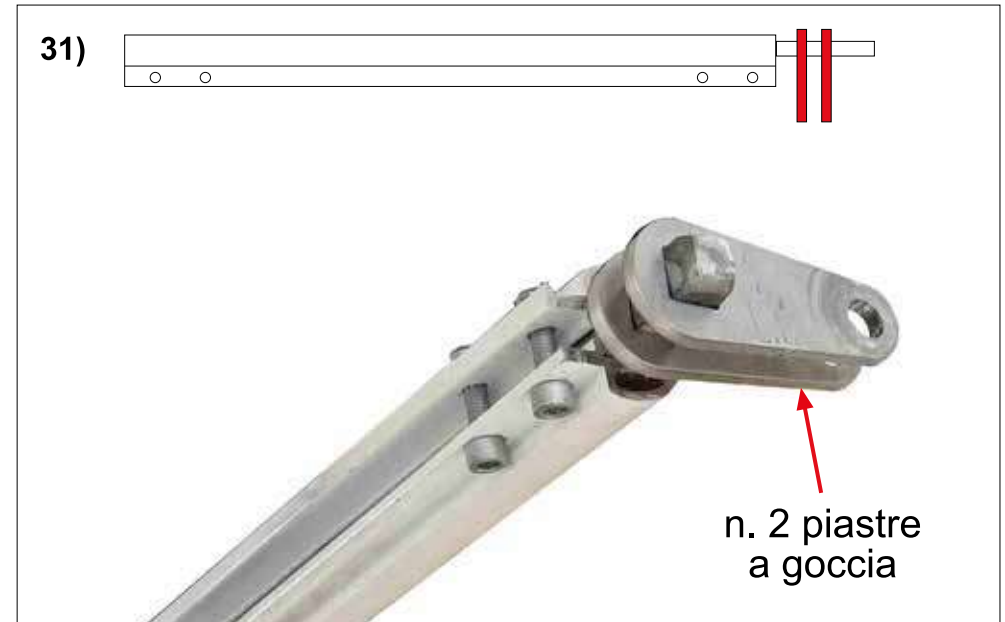
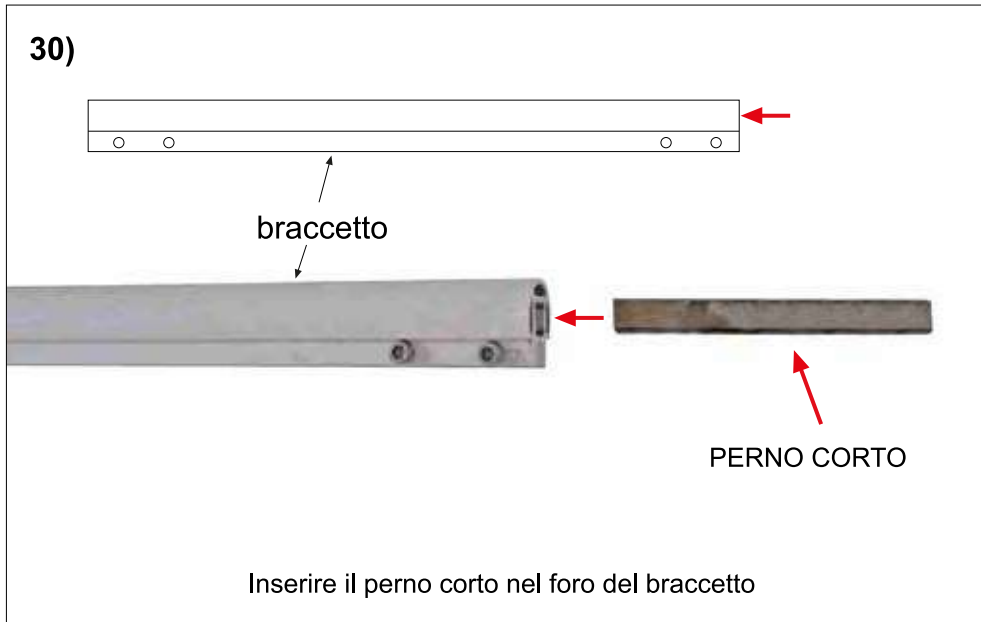

17 Inserire il perno lungo dall'altro lato del braccetto facendolo passare prima attraverso il foro della trave frangitratta.

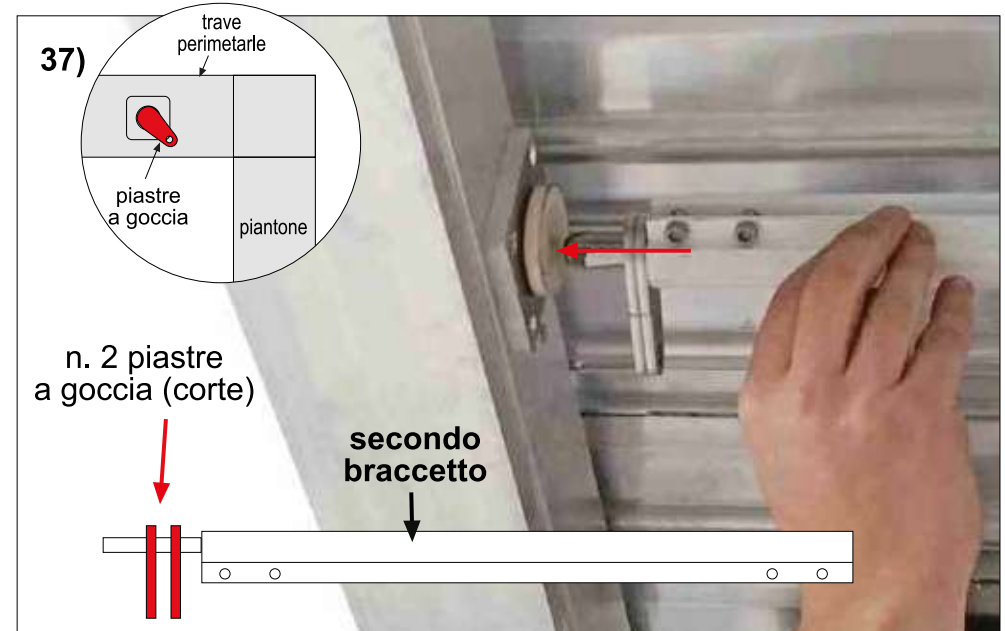
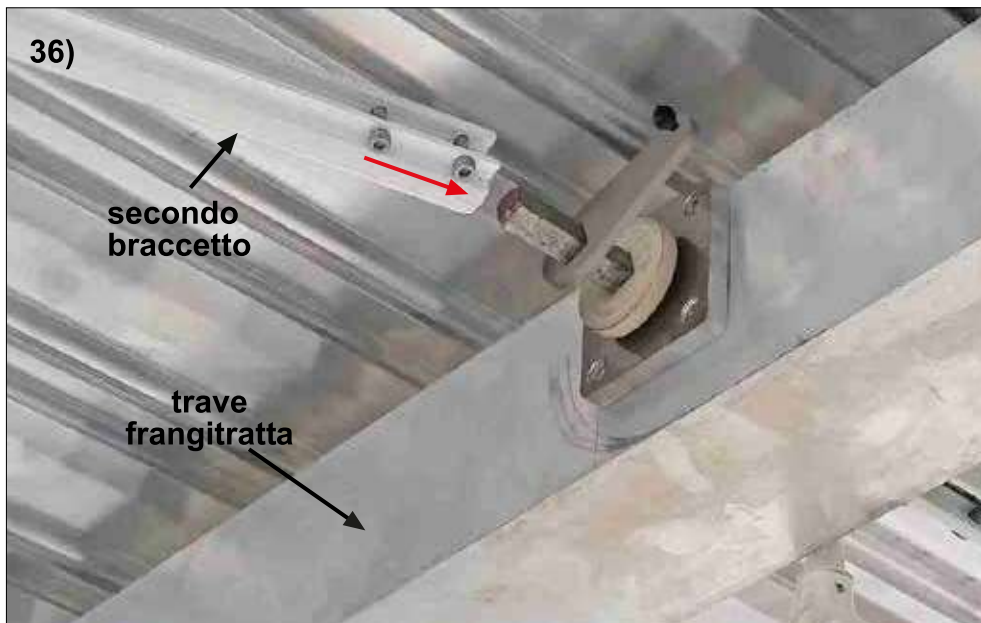
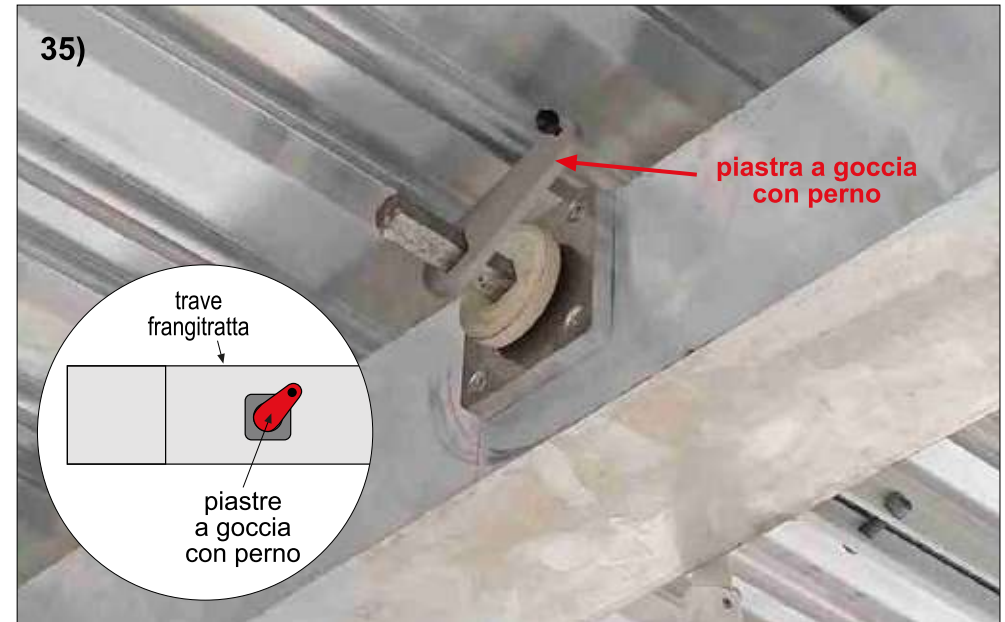

38)

Stringere i bulloni dei braccetti per bloccare i perni



39)

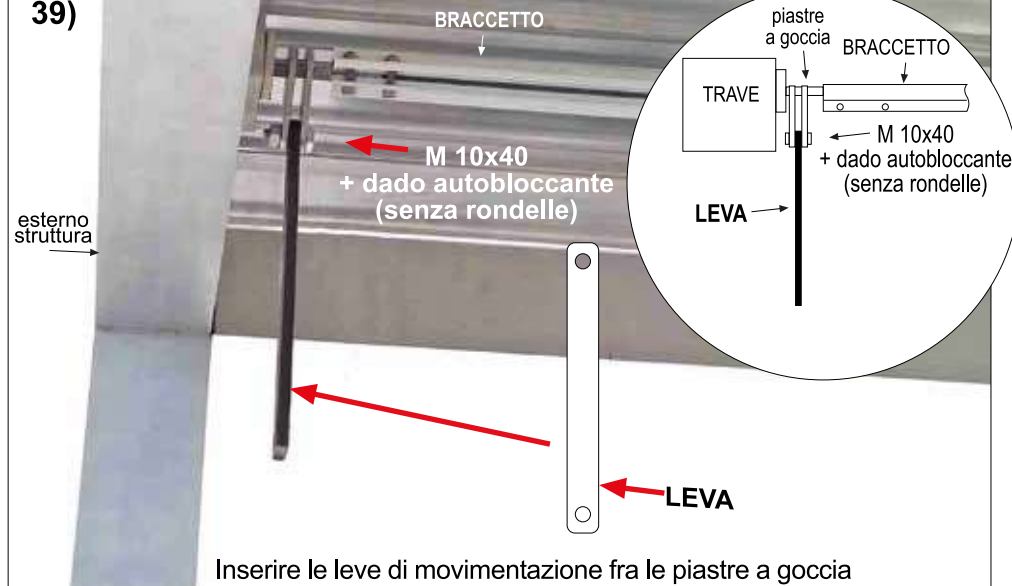

40)

3^a lama

LEVA

Collegare la leva alla piastra triangolare della terza lama e bloccala con il bullone

M 10x30 + dado autobloccante (senza rondelle)







La struttura è completa.
Ruotare l'asta per aprire e chiudere le lame.